

1 1/2" DEEP U.S.C.G. APPROVED MOLDED PHENOLIC GRATING

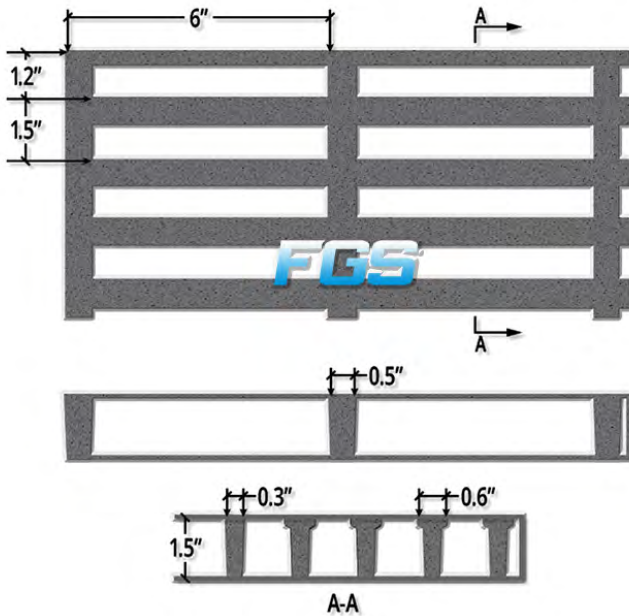

Bars ▶ 8
Open Area ▶ 55%
Load Bar Width ▶ 0.6"
Load Bar Centers ▶ 1.5"

Approximate Weight ▶ 4.00 lbs/ft²

Engineering Properties Per Foot of Width

A ▶ 4.39 in² I ▶ 0.88 in⁴ S_T ▶ 1.30 in³ S_B ▶ 1.06 in³

UNIFORM LOAD DEFLECTION

	50 lbs/ft ²	100 lbs/ft ²	200 lbs/ft ²	500 lbs/ft ²	750 lbs/ft ²	1000 lbs/ft ²	1500 lbs/ft ²	2000 lbs/ft ²	Maximum Load	Apparent EI x 10 ⁻⁶ (Lbs/in ²)
12" SPAN ▶	<0.01	<0.01	<0.01	<0.01	<0.01	<0.01	0.02	0.03	▶ 7560	1.39
18" SPAN	<0.01	<0.01	<0.01	0.01	0.02	0.03	0.06	0.12	▶ 3360	1.87
24" SPAN ▶	<0.01	0.02	0.03	0.03	0.04	0.08	0.17	0.34	▶ 1890	2.13
30" SPAN	0.02	0.04	0.06	0.08	0.10	0.20	0.39	---	▶ 1210	2.24
36" SPAN ▶	0.04	0.08	0.12	0.16	0.20	0.40	---	---	▶ 840	2.28
42" SPAN	0.07	0.15	0.22	0.29	0.36	---	---	---	▶ 617	2.32
44" SPAN ▶	0.09	0.17	0.26	0.35	0.43	---	---	---	▶ 562	2.34
48" SPAN	0.12	0.24	0.37	0.49	0.61	---	---	---	▶ 473	2.36
54" SPAN ▶	0.19	0.39	0.58	---	---	---	---	---	▶ 373	2.39

CONCENTRATED LINE LOAD DEFLECTION

	50 lbs/ft ²	100 lbs/ft ²	150 lbs/ft ²	200 lbs/ft ²	250 lbs/ft ²	500 lbs/ft ²	1000 lbs/ft ²	2000 lbs/ft ²	Maximum Load	Apparent EI x 10 ⁻⁶ (Lbs/in ²)
12" SPAN ▶	<0.01	<0.01	<0.01	<0.01	<0.01	0.01	0.03	0.05	▶ 3780	1.39
18" SPAN	<0.01	<0.01	<0.01	0.01	0.02	0.03	0.06	0.13	▶ 2520	1.87
24" SPAN ▶	<0.01	0.01	0.02	0.03	0.03	0.07	0.14	0.27	▶ 1890	2.13
30" SPAN	0.01	0.03	0.04	0.05	0.06	0.13	0.25	0.50	▶ 1512	2.24
36" SPAN ▶	0.02	0.04	0.06	0.09	0.11	0.21	0.43	---	▶ 1260	2.28
42" SPAN	0.03	0.07	0.10	0.13	0.17	0.33	0.66	---	▶ 1080	2.32
44" SPAN ▶	0.04	0.08	0.11	0.15	0.19	0.38	---	---	▶ 1031	2.34
48" SPAN	0.05	0.10	0.15	0.20	0.24	0.49	---	---	▶ 945	2.36
54" SPAN ▶	0.07	0.14	0.21	0.27	0.34	0.69	---	---	▶ 840	2.39

- ▶ These tables were developed in accordance with the test method developed by the *Fiberglass Grating Manufacturers Council (FGMC)* of the *American Composites Manufacturers Association (ACMA)* for the Fiberglass Grating Standard.
- ▶ The designer should not exceed MAXIMUM RECOMMENDED load at any time. MAXIMUM LOAD represents a 5:1 factor of safety on ULTIMATE CAPACITY. ULTIMATE CAPACITY represents MAX LOAD observed at initial fracture.
- ▶ Walking loads for maintenance traffic are typically a live load of 50 PSF. Deflections for worker comfort are typically limited to 3/8" or SPAN divided by 120 under full live load. For a firmer feel under full live load or a line load 250 lbs/ft of width, limit deflections to 1/4" or SPAN divided by 200.
- ▶ The loads represented are for STATIC LOAD CONDITIONS at ambient temperature. Deflection for impact loads or dynamic loads will MULTIPLY the deflections shown by 2. Long term loads will result in added deflection due to creep in the material and will require higher factors of safety to ensure acceptable performance.
- ▶ Deflections are limited to 1/2" as recommended by the *Fiberglass Grating Manufacturers Council* of the *American Composites Manufacturers Association*.
- ▶ For applications at elevated temperatures, consult Fiberglass Grating Systems.